

THIS DRAWING IS UNPUBLISHED. RELEASED FOR PUBLICATION
 © COPYRIGHT BY TYCO ELECTRONICS CORPORATION. ALL RIGHTS RESERVED.

LOC	DIST	REVISIONS			
P	LTR	DESCRIPTION	DATE	DWN	APVD
GP	00	M	REVISED PER ECO-06-026024	7 MAR 07	AWF AWF

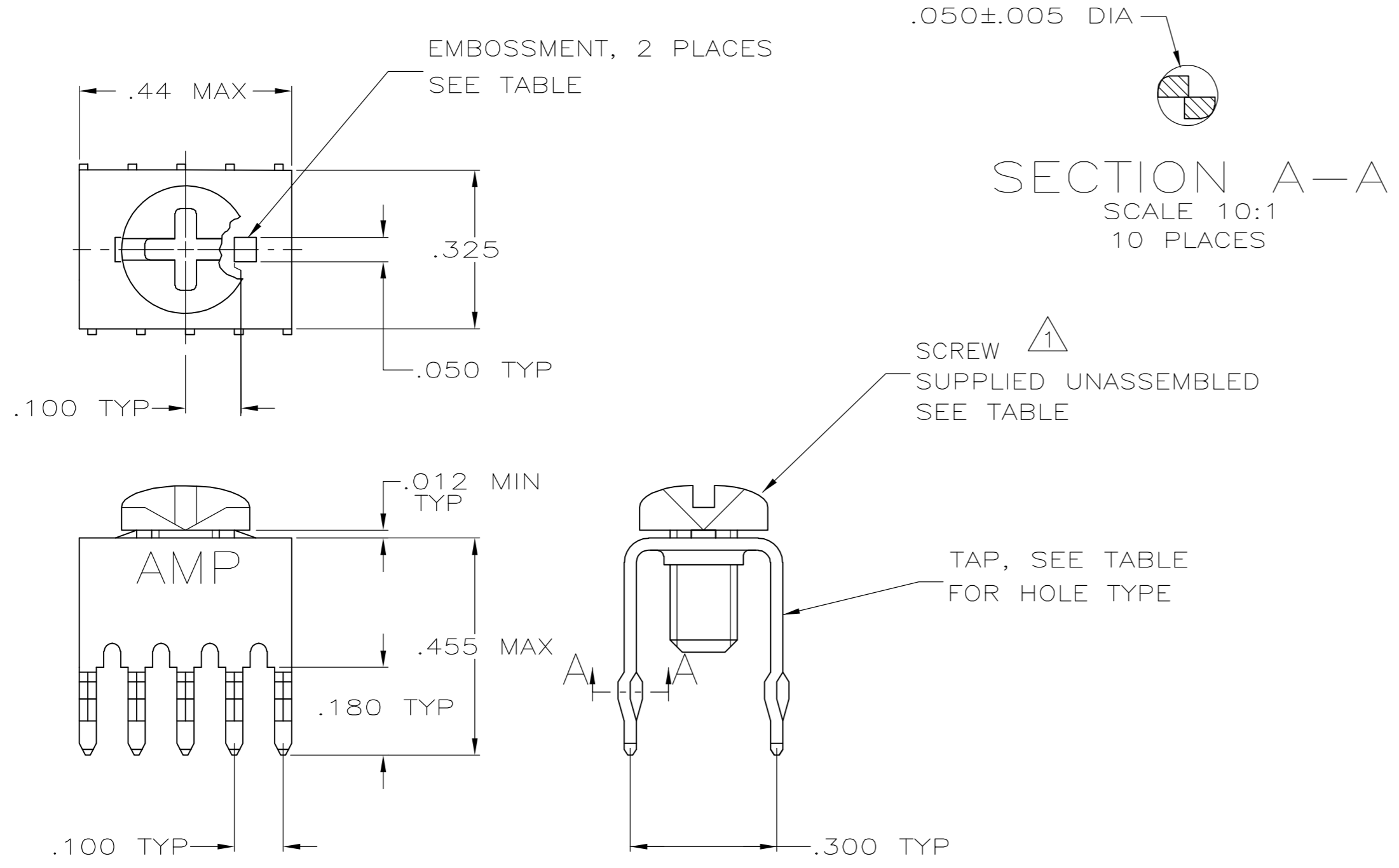

- ¹ TO PREVENT THREAD STRIPPING, SCREW TORQUE SHOULD NOT EXCEED 9 IN LBS.
- ² TAP HOLE IS 6-32UNC-2B, TWO MIN THREADS.
- ³ TAP HOLE IS M4 X 0.7, TWO MIN THREADS.
- ⁴ TAP: .000150 TIN-LEAD OVER .000050 NICKEL.
- ⁵ TAP: .000150 TIN OVER .000050 NICKEL.

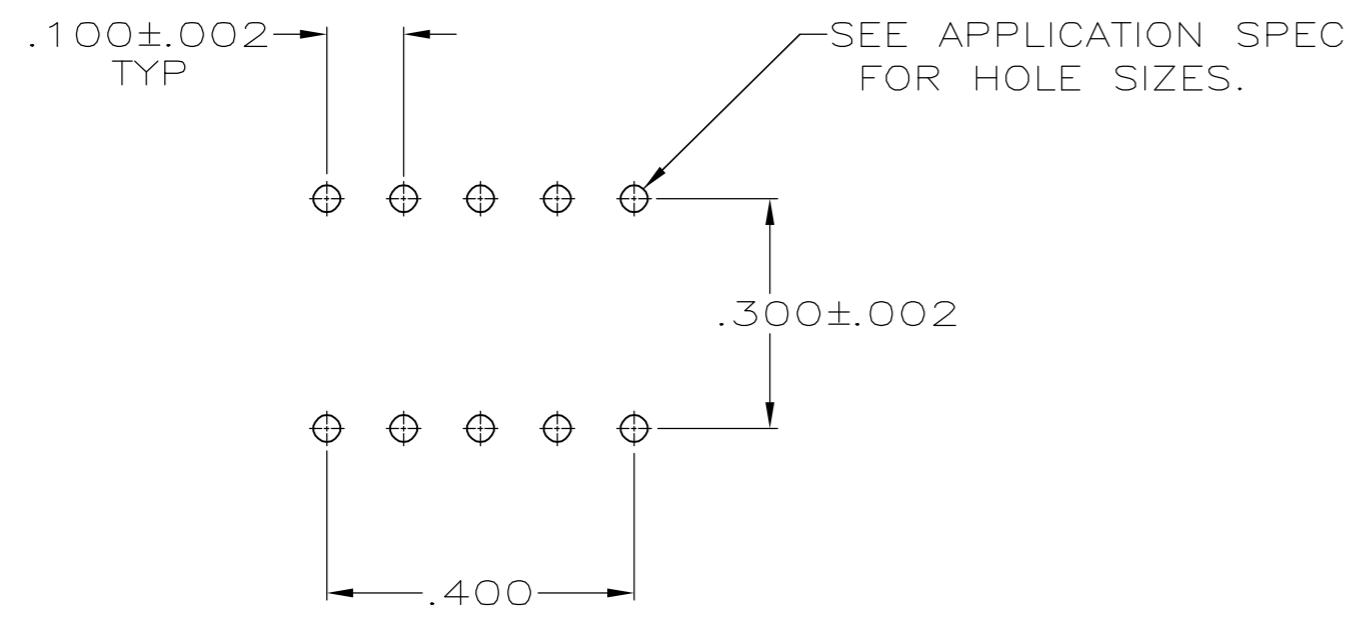

	FINISH	HOLE TYPE	SCREW	EMBOSSMENT	PART NUMBER
OBSOLETE	⁵	²	993879-1	YES	9-55558-1
OBSOLETE		²	NO	YES	9-55558-0
SUPERSEDED BY -4	⁴	³	NO	YES	1-55558-1
		²	993879-1	NO	55558-8
	⁴	²	NO	NO	55558-7
		²	993879-1	YES	55558-4
		²	NO	YES	55558-3

THIS DRAWING IS A CONTROLLED DOCUMENT.		DWN J. McCLINTON 1-11-88	Tyco Electronics Corporation Harrisburg, PA 17105-3608	
DIMENSIONS: INCHES	TOLERANCES UNLESS OTHERWISE SPECIFIED:	CHK R. STONE 1-11-88	NAME M. GALLOWAY 1-11-88	
	0 PLC ± - 1 PLC ± - 2 PLC ± - 3 PLC ± .008 4 PLC ± - ANGLES ± - FINISH ⁴ / ⁵	APVD M. GALLOWAY 1-11-88	PRODUCT SPEC -	
MATERIAL COPPER ALLOY 725.		APPLICATION SPEC 114-11000	SIZE A2	CAGE CODE 00779
		WEIGHT -	DRAWING NO C=55558	RESTRICTED TO -
		CUSTOMER DRAWING	SCALE 4:1	SHEET 1 of 1